

# SWIMMING POOL AIR MANAGEMENT

DanX

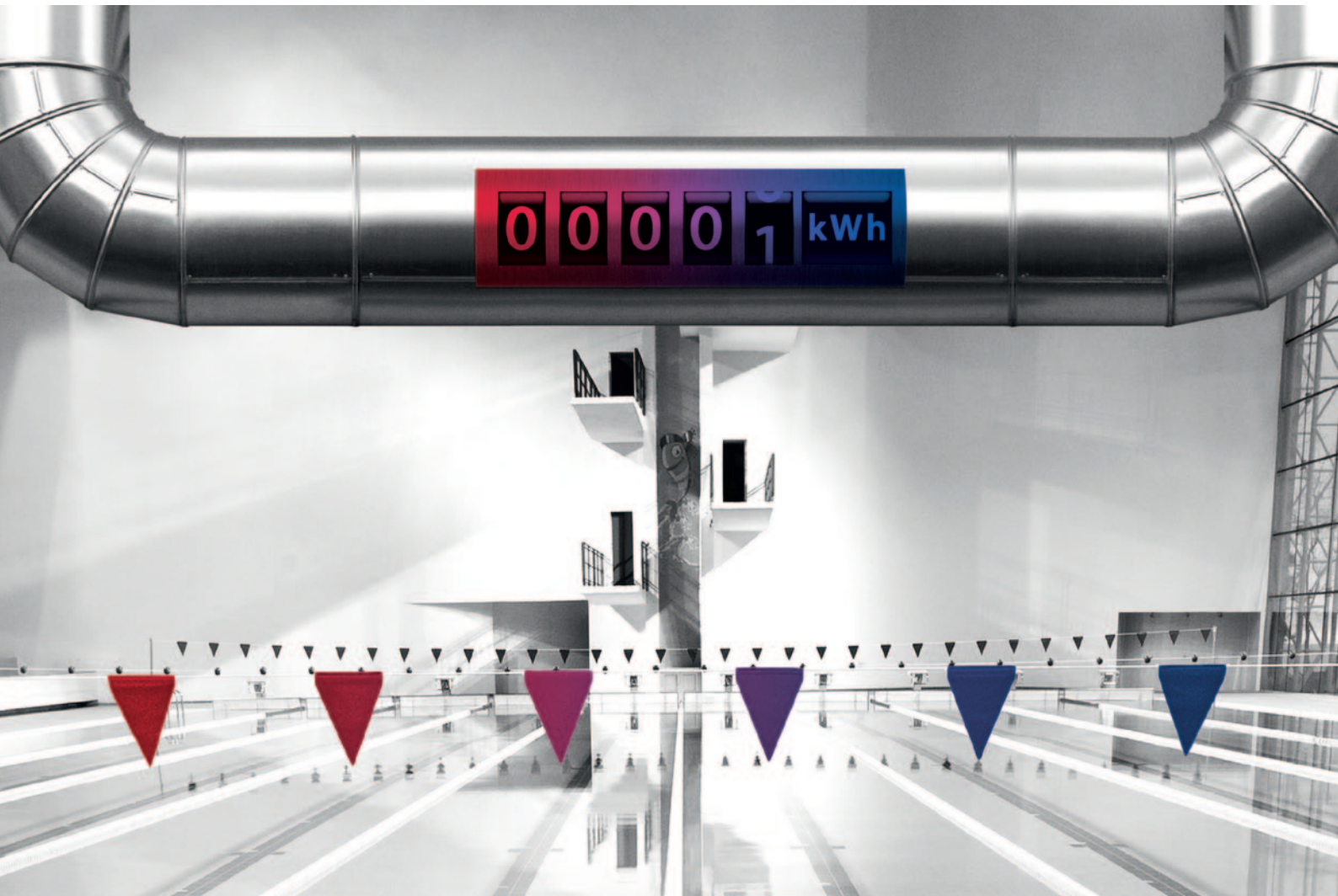

**Dantherm**<sup>®</sup>  
CONTROL YOUR CLIMATE

# SWIMMING POOL AIR MANAGEMENT

## Comfortable swimming in every climate

A quick dip in the pool feels great. But the air quality in indoor swimming pool areas can be trying – for people, furnishings and your building. Traditional dehumidifiers can help control relative air humidity. But if you really want to provide a pleasant environment around your pool – no matter the conditions – you'll need a solution that combines dehumidifying, temperature control and ventilation.

A complete solution like the DanX offers a wide range of benefits – from greatly improved air quality and no chlorine smell in the pool room, to options for free cooling in summer and very high dehumidification capacity during winter, when condensation problems can be serious.

It is impossible to avoid water evaporation in swimming pool halls, however using a carefully designed ventilation solution, the relative humidity can be controlled to a comfortable level. On the basis of pool size, water temperature, air temperature, humidity and bathing activity, Dantherm's DanX can be designed to accommodate any requirement. Available with a one or two stage heat recovery system and a bespoke controls package, it is the ideal device for providing energy- and cost effective control of swimming pool hall environments – anywhere in the world.

### Developed to endure

The DanX units have been specifically designed and developed to endure the aggressive environment encountered in swimming pools. The optional powder coating of framework and all internal surfaces, treated coils and a cross flow heat exchanger of anodized and epoxy coated aluminium also protect the DanX unit against any kind of corrosion.

### Focus on cost of ownership

The DanX provides for life cycle costs in the broadest sense. Highly efficient heat recovery and low specific fan power, combined with an optimized control strategy, contribute to cost-efficient operation and significant energy savings. While durable components ensure reliable operation and long life. Ultimately, all of this results in savings in the long run and contributes to a low cost of ownership.

The solutions are ideal for leisure, municipal and commercial projects in every climate around the world – and our reference list includes a wide variety of projects. From massive water fun areas and luxurious hotel pools to spa resorts, health resorts and traditional swimming pool halls.

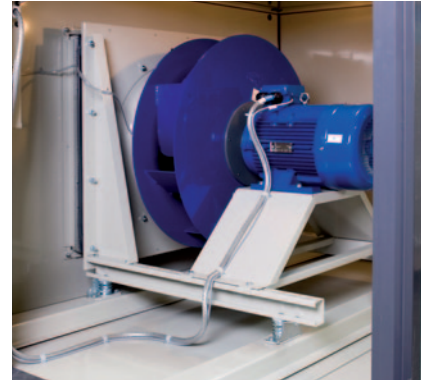

*Dantherm's powder coating provides by far the best corrosion resistance on the market, as all cabinet and other sheet components are powder coated after manufacturing but before the assembling process.*



*Efficient heat exchangers made from epoxy-coated aluminium, making them thoroughly resistant to harsh chlorine-tainted air.*



*The DanX units are equipped with Heat Exchangers produced by HEATEX who participates in the Eurovent Certification programme for Heat Exchangers. Check ongoing validity of certificate on [www.eurovent-certification.com](http://www.eurovent-certification.com) or using [www.certiflash.com](http://www.certiflash.com).*

### DanX XWPS with heat pump and cross flow heat exchanger

The DanX XWPS combines the best advantages of a heat pump and an outside air dehumidification system. The combination of heat pump and highly efficient cross flow heat exchanger is designed to perfectly control the humidity and indoor temperature.

Significant running cost reductions due to energy savings of up to +100%. The integrated mixing function ensures that only the exact quantity of outside air required to sustain comfortable conditions is supplied.

### DanX XWP with reversible heat pump and crossflow heat exchanger

The DanX XWP includes the same combination of heat pump and cross flow heat exchanger as the XWPS. Thereby also the same benefits and advantages. But as the heat pump is reversible, it offers both the comfort of cooling and of increased dehumidification.

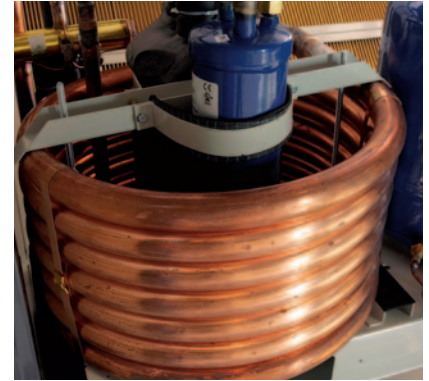

### Shared benefits

Applicable for both DanX XWPS and DanX XWP for further energy optimization, a water cooled condenser can be integrated into the heat pump. This allows the excess heat to be transferred to the pool or the hot water supply, where it is efficiently re-used.

Free cooling is also an option during summer, when the unit can add up to 100% outside air into the pool area through the integrated by-pass.

At night, when the evaporation rate is low and fresh air supply is redundant, the system can switch to full recirculation, allowing the system to act wholly or partly as a dehumidifier.

### DanX XWPS

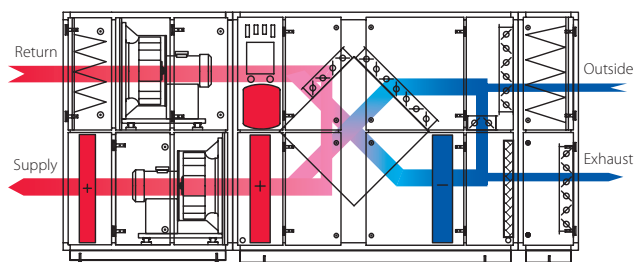

#### Daytime winter:

A proportion of recirculation air, with heating, 2 stage heat recovery and dehumidification with heat pump and outside air.

### DanX XWP

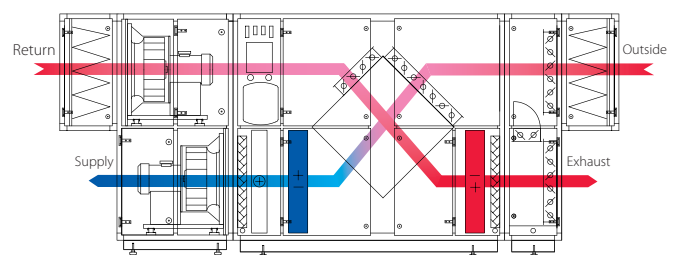

#### Daytime summer:

100% proportion of outside air. Free cooling through the by-pass and/or heat pump in cooling mode.

**DanX XKS with cross flow heat exchanger**

The DanX XKS is a very effective outside air dehumidification system with highly efficient cross flow heat exchanger. This system perfectly controls the humidity and indoor temperature while offering significant running cost reductions due to real energy savings of up to 80%. The integrated mixing function ensures that only the exact quantity of outside air needed is supplied – which keeps running costs at a minimum.

Free cooling is also an option during summer, when the unit can add up to 100% outside air into the pool area through the integrated by-pass.

For countries with high outside summer temperatures the system can be equipped with an additional cooling coil for further dehumidification and air cooling.

Optionally a large variation of fan types, filter qualities and coils are offered for the perfect match to the requirements.

**DanX AF with heat pump**

The DanX AF is a very effective heat pump dehumidification system, which perfectly controls the humidity and indoor temperature while offering significant running cost reductions. This system is the obvious choice where only limited space is available, or for pools with limited use, for instance hotel pools. Optionally it is also possible to install the unit suspended under the ceiling of the pool room.

For further energy optimization, a water cooled condenser can be integrated into the heat pump. This allows the excess heat to be transferred to the pool or the hot water supply, where it is efficiently reused.

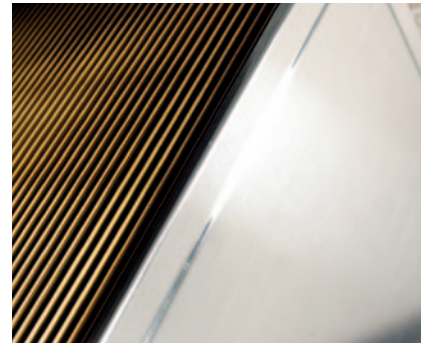

*Dantherm's epoxy-coated aluminum cross flow heat exchanger is not only very efficient, but also highly resistant to the aggressive swimming pool environment.*



**DanX XKS**

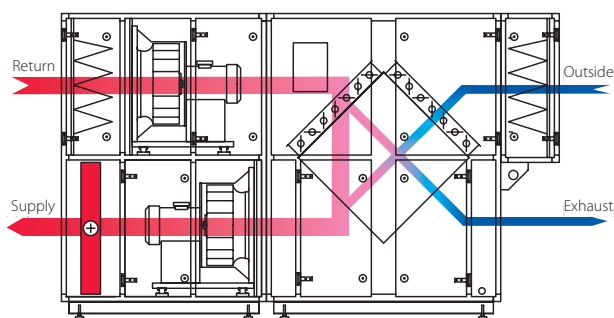

**Nighttime/daytime winter:**

*A proportion of recirculation air with heating, 1 stage heat recovery and dehumidification with outside air.*

**DanX AF**

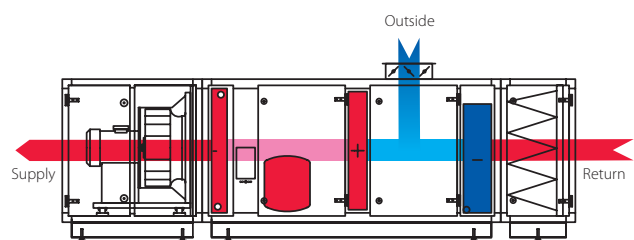

**Daytime:**

*Recirculation with heating and dehumidification with heat pump and a proportion of outside air.*

**DanX HP with double cross flow heat exchanger and heat pump**

The DanX HP combines the strengths of a heat pump system with a system that dehumidifies using outside air. The combined heat pump and highly effective double cross flow heat exchanger precisely regulate both humidity and temperatures in the pool room.

In addition to heat recovery exceeding 100%, the heat pump optimises dehumidification, so that the proportion of outside air never exceeds what is necessary to ensure comfort.

For further energy optimization, a water cooled condenser can be integrated into the heat pump. This allows the excess heat to be transferred to the pool or the hot water supply, where it is efficiently reused.

**DanX XD with double cross flow heat exchanger**

The DanX XD is a very effective ventilation system that uses outdoor air to provide dehumidification using a double heat exchanger that delivers up to a 95% heat recovery. This reduces energy consumption and total operating costs. Making the unit perfect for managing humidity and temperature in the pool room.

**For both DanX HP and DanX XD**

The built-in mixing function takes care not to add any more outdoor air than necessary to provide a comfortable indoor climate. Free cooling is also an option during summer, when the unit can add up to 100% outside air into the pool area through a by-pass.



**Materials**

- 50 mm sandwich panels
- Corrosion proof construction with powder coating internally and externally
- Epoxy coated heat exchangers
- High quality components

**DanX HP**

Return Supply Outside Exhaust

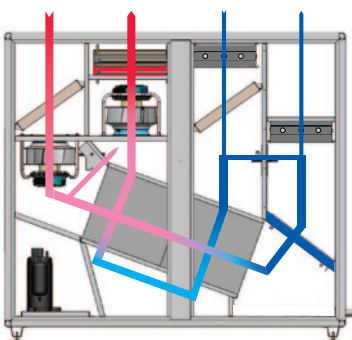

**Daytime winter:**

Partial recirculation with heating, 2-stage heat recovery and dehumidification with outside air and heat pump. To minimise pressure loss, only some of the humid return air is conducted through the heat exchanger for evaporation. If dehumidification is insufficient, the proportion of dry outside air is increased automatically.

**DanX XD**

Return Supply Outside Exhaust

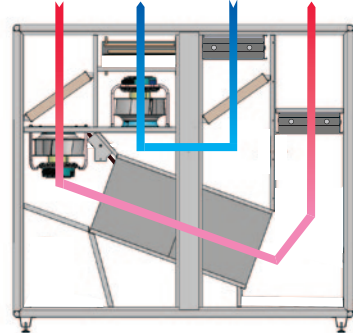

**Daytime summer:**

The DanX XD is running with 100% outside air. The reheater will normally be stopped as the temperature is high enough, after been pre heated in the double cross flow heat exchanger. If the outside temperature goes further up a by pass will open to run the unit in free cooling mode.

## Energy saving solutions

The DanX 2 and 3 are complete solutions that deliver exceptional indoor comfort using very little energy. Developed especially for hotels, wellness centres and private indoor swimming pools.

Ensuring a comfortable, healthy indoor climate is obviously the most important job for a system like this, as this protects both the people who use the pool and your physical assets. But operating costs are equally important, and the DanX 2 and 3 are extraordinarily efficient.

We have built energy savings into every detail, with all components chosen to ensure high capacity and a long service life. The system lets you add as much as 100% outside air. Double cross flow heat exchanger that delivers up to 95% heat recovery combined with low-energy EC fan motors and optimal, high efficiency compressor ensure the lowest possible operating costs.

The choice of quality materials and effective corrosion resistance protect the DanX against tough pool room environments and ensure a long service life.

## Conveniently compact

The installation costs can be kept to an absolute minimum for the DanX 2 and 3. The ultra-compact unit comes fully assembled, with built-in after heating coil and control system. All you really need to do is plug the unit in and connect it to your duct system, and it is ready to get to work.

The units' compact, integrated design enables optimal installation in the technical room. Convenient top or side connections ensure easy access to ducts.



## Benefits

- High quality and energy efficiency ensures very low LCC
- Complete solution providing ultimate comfort
- Up to 100% outside air with free cooling in summer
- Effective double cross flow heat exchangers with up to 95% heat recovery efficiency
- Low-energy EC fan motors
- Effective corrosion resistance ensures long service life
- Ultra-compact unit with built-in after heating coil and control system
- Flexible installation with a range of connection options

## Product range:

DanX	Nominal air volume (m³/h)	Dehumidification <sup>1</sup> (kg/h)	Dehumidification <sup>2</sup> (kg/h)
HP / XD 2	1750	9 / 6	11/11
HP / XD 3	2750	15 / 10	18/18
XWPS-XWP/XKS 2/4	3350	17 / 12	22/22
XWPS-XWP/XKS 3/6	4500	26 / 16	29/29
XWPS-XWP/XKS 5/10	8400	45 / 30	54/54
XWPS-XWP/XKS 7/14	12500	65 / 44	81/81
XWPS-XWP/XKS 9/18	15500	81 / 55	100/100
XWPS-XWP/XKS 12/24	21500	122 / 76	139/139
XWPS-XWP/XKS 16/32	25500	137 / 90	165/165

<sup>1</sup>Pool hall condition 30°C/54% r.h. - 30% outside air @ 5°C/85% r.h.

<sup>2</sup>Max. in accordance to VDI 2089 at 30°C/54% r.h. pool hall condition.

DanX	Nominal air volume (m³/h)	Dehumidification <sup>1</sup> (kg/h)
AF 3/6	4850	30
AF / AFs 5/10	7300 / 9500	47 / 59
AF / AFs 7/14	12000 / 14000	76 / 90
AF / AFs 12/24	19000 / 24000	120 / 148

<sup>1</sup>Pool hall condition 30°C/54% r.h. - 30% outside air @ 5°C/85% r.h.

# INTELLIGENT CONTROL SYSTEM

## User friendly control system

All DanX systems are supplied with a control package, which takes demand management to a new level. Based on years of experience and on-going development, the control strategy has been optimized specifically for Dantherm swimming pool units. With automatic monitoring and control of temperature, humidity and energy consumption, you are guaranteed a balanced and comfortable indoor climate – adapted to your specific requirements.

The DanX unit is supplied ready wired and with all necessary sensors and safety devices installed. All control current components such as temperature sensors, damper motors, solenoid valves, motor valves etc. are connected to a terminal.

To make it as easy as possible to establish the electrical connection between the control panel and the DanX unit, the unit can be delivered with pre-mounted cables.

The control system combines intuitive, hassle-free operation with extremely advanced control and programming options. The result is highly precise demand management – which is the secret to unprecedented low operating costs for the DanX line.

A large, easy-to-read display makes it easy to check settings and current status. And a few simple buttons let you quickly and easily programme the unit to suit your own preferences. Control over every single function is at your fingertips.

The controller has a built-in communication capability, allowing it to be integrated into a Building Management System.

## Benefits

- Newly developed, effective, demand control
- Intuitive, logical operations
- Precise, intelligent control
- Easy-to-read display
- Complete logical control
- Fully factory tested system



**ELECTRONICS COOLING**

**DEHUMIDIFICATION**

**VENTILATION**

**MOBILE HEATING AND COOLING**

Dantherm is a market-leading supplier of energy-efficient climate control solutions for customers across the globe. Our subsidiaries in Norway, Sweden, Germany, the UK, the US and China and our representative office in Russia unite approx. 600 employees. We operate in the following four main business areas:

**Electronics cooling:**

Climate control for electronics and battery cooling in radio base stations and other Telecom infrastructure. Telecom customers include network suppliers and network operators.

**Dehumidification:**

Mobile and stationary dehumidifiers for drying buildings and for use in private pools and wellness centres.

**Ventilation:**

Large ventilation systems used in swimming pools and buildings such as shopping centres and cinemas requiring frequent air change. The range also includes domestic ventilation products based on high-performance heat exchangers.

**Mobile heating and cooling:**

Products for heating or cooling of tents and equipment used by the armed forces and aid organisations. The customers are primarily the armed forces in NATO countries as well as tent and container manufacturers.

**Dantherm Air Handling A/S**

Marienlystvej 65  
DK-7800 Skive, Denmark  
Tel. +45 96 14 37 00  
Fax +45 96 14 38 20  
info@dantherm.com

